

UNIVERSAL JOINTS

General Light Series Joints

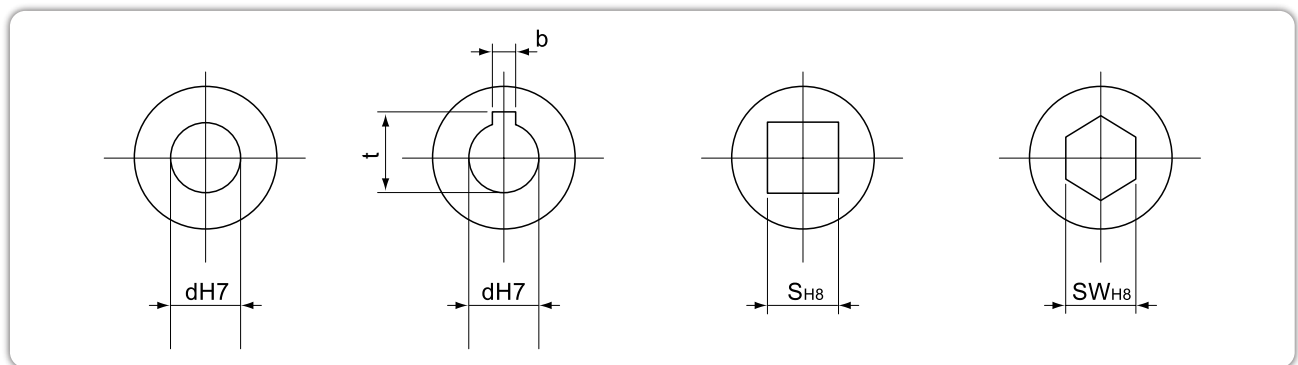
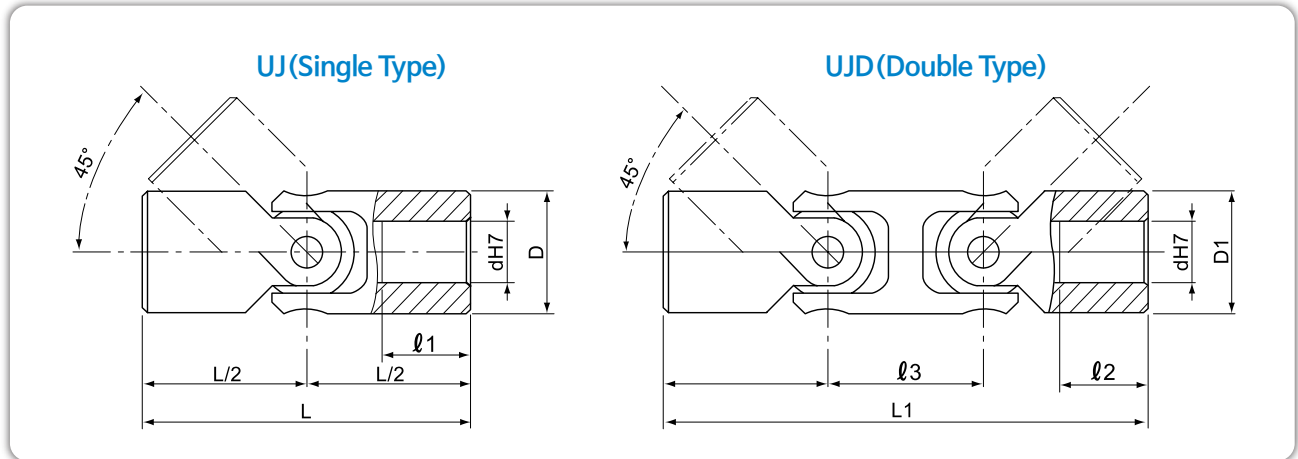

Universal joints are available in circular, key way, square, or hexagon shapes, and production by drawing is also possible.

TYPE		d	D	D1	L	L1	l1	l2	l3	S	SW	bxt
Single	Double											
WCC-UJ 05	-	5	13	-	40	-	13	-	-	-	-	-
WCC-UJ 06	-	6	13	-	40	-	13	-	-	6	-	-
WCC-UJ 08	-	8	16	-	40	-	10	-	-	8	-	2 x 9
WCC-UJ 10	-	10	20	-	62	-	19	-	-	10	10	3 x 11.4
WCC-UJ 12	UJD-12	12	25	25	74	86	23	19	33	12	12	4 x 13.8
WCC-UJ 14	UJD-14	14	29	29	74	95	23	21	33	14	14	5 x 16.3
WCC-UJ 16	UJD-16	16	32	32	86	104	26	21	35	16	16	5 x 18.3
WCC-UJ 18	UJD-18	18	37	37	120	180	41	54	39	18	18	6 x 20.8
WCC-UJ 20	UJD-20	20	40	40	108	128	32	21	46	20	20	6 x 22.8
WCC-UJ 22	UJD-22	22	47	47	130	200	41	54	46	22	-	6 x 24.8
WCC-UJ 25	UJD-25	25	50	50	132	163	41	25	59	25	25	8 x 28.3
WCC-UJ 30	UJD-30	30	58	58	166	182	52	30	66	30	30	8 x 33.8
WCC-UJ 35	UJD-35	35	70	70	140/200	212/310	35/65	30/79	78	AS ON REQUEST		
WCC-UJ 40	UJD-40	40	80	80	160/228	245/350	42/76	38/90	95			
WCC-UJ 50	UJD-50	50	95	95	190/270	290/426	54/94	50/118	120			

Slip Shafts Series Joints

UJS (Slip Shaft Type)

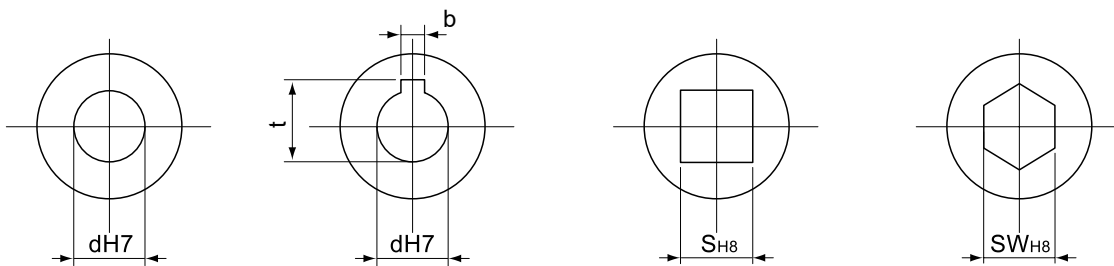
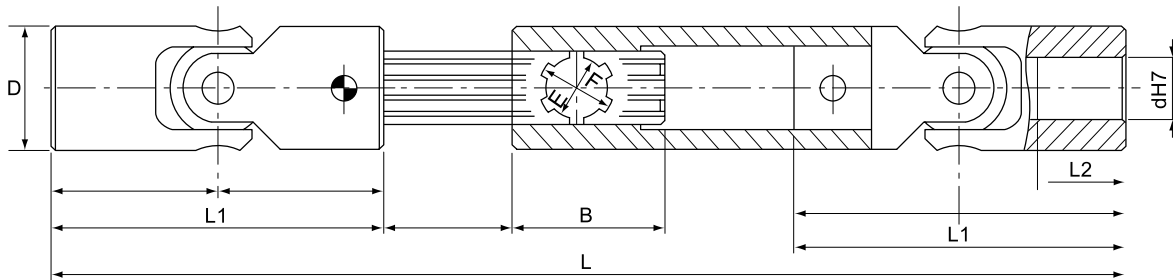

Universal joints are available in circular, key way, square, or hexagon shapes, and production by drawing is also possible. Spline work, heat treatment, polishing work is also possible.

TYPE	d	D	L1	L2	B	E/F	S	SW	bxt
WCC-UJS 10	10	22	45	10	40	11/14	10	10	3 x 11.4
WCC-UJS 12	12	25	50	11	45	13/16	12	12	4 x 13.8
WCC-UJS 14	14	29	56	13	48	13/16	14	14	5 x 16.3
WCC-UJS 16	16	32	65	15	50	16/20	16	16	5 x 18.3
WCC-UJS 18	18	37	72	17	51	16/20	18	18	6 x 20.8
WCC-UJS 20	20	40	82	19	56	18/22	20	20	6 x 22.8
WCC-UJS 22	22	47	95	22	60	21/25	22	22	6 x 24.8
WCC-UJS 25	25	50	108	27	69	23/28	25	25	8 x 28.3
WCC-UJS 30	30	58	122	30	70	26/32	30	30	8 x 33.8
WCC-UJS 35	35	70	140	35	70	28/35	35	35	10 x 38.3
WCC-UJS 40	40	80	160	42	75	33/40	40	40	12 x 43.3
WCC-UJS 50	50	95	190	54	80	43/50	50	50	14 x 53.8

※ Equation to obtain length "L"
 min. $L = (2 \times L1) + B + C$
 max. $L = (2 \times L1) + B + (2 \times C)$
 C-max. L-min. L

Service Factor and Reference

Service Factor

The service factors listed are the typical values used for normal operation of drive systems. If the applications use repetitive high peak loads, choose a factor by using the provided instructions or formulas.

Table 1

<p>Aphabetical listing of applications</p> <p>AERATOR2.5</p> <p>AGITATORS</p> <p>Vertical and Horizontal screw,propeller,Paddle1.5</p> <p>BARGE HAUL PULLER3.0</p> <p>BLOWERS</p> <p>Centrifugal1.5</p> <p>Lobe or Vane1.75</p> <p>CAR DUMPERS4.0</p> <p>CAR PULLERS2.5</p> <p>CLARIFIER OR CLASSIFIER1.5</p> <p>COMPRESSORS</p> <p>Centrifugal1.1</p> <p>Rotary,Lobe or Vane2.0</p> <p>Rotary,Screw2.0</p> <p>Reciprocation</p> <p>Direct,Connected ★</p> <p>With out Flywheels ★</p> <p>*With flywheel and Gear between Compressor and Prime Mover</p> <p>1 cylinder,single acting5.0</p> <p>1 cylinder,double acting5.0</p> <p>2 cylinders,single acting5.0</p> <p>2 cylinders,double acting5.0</p> <p>3 cylinder,single acting5.0</p> <p>3 cylinder,double acting3.0</p> <p>4 or more cyl., single act3.5</p> <p>4 or more cyl., double act3.5</p> <p>CONVEYORS</p> <p>Apron,Assembly,Belt,Chain Flight,Screw1.5</p> <p>Bucket2.0</p> <p>Live Roll,Shaker and Reciprocation3.5</p> <p>▲★CRANES AND HOIST</p> <p>Main Hoist5</p> <p>Skip Hoist2.5</p> <p>Slope2.25</p> <p>Bridge,Travel or Trolley5</p> <p>DYNAMOMETER1.5</p> <p>ELEVATORS</p> <p>Bucket,Centrifugal Discharge2.0</p> <p>Freight or Passenger(Not Approved)</p> <p>Gravity discharge2.0</p> <p>ESCALATORS(Not Approved)</p> <p>EXCITER GENERATOR1.75</p> <p>EXTRUDER, PLASTICI2.25</p>	<p>FANS</p> <p>Centrifugal1.1</p> <p>Cooling Tower3.0</p> <p>Forced Draft-Across the Line start2.0</p> <p>Forced Draft Motro Driven thru fluid or electric slip clutch1.5</p> <p>Gas Recirculating2.5</p> <p>Induced Draft with damper control or blade cleaner2.0</p> <p>Induced Draft without controls3.0</p> <p>FEEDERS3.0</p> <p>Apron,Belt,Disc,Screw2.0</p> <p>Reciprocation3.5</p> <p>GENERATORS</p> <p>Even Load1.1</p> <p>Hoist or Railway Service2.0</p> <p>Welder Load3.0</p> <p>HAMMERMULL2.5</p> <p>LAUNDRY WASHER OR TUMBLER3.0</p> <p>LINE SHAFTS</p> <p>Any processing Machinery2.0</p> <p>MACHINE TOOLS</p> <p>Auxiliary and Traverse Drive1.5</p> <p>Bending Roll,Notching press. Punch Press, Planer, Plate Reversing2.5</p> <p>Main Drive2.0</p> <p>MAN LIFTS(Not Approved)</p> <p>METAL FORMING MACHINES</p> <p>Draw Bench Carriage and Main Drive3.0</p> <p>Extrude3.0</p> <p>Forming Machine and Forming Mills3.0</p> <p>Slitters1.5</p> <p>Wire Drawing or Flattening2.5</p> <p>Wire Winder2.25</p> <p>Coilers and Uncoilers2.25</p> <p>MIXERS (see Agitators)</p> <p>Concrete2.5</p> <p>Muller2.5</p> <p>PRESS,PRINTING2.25</p> <p>PUG MILL2.5</p> <p>PULVERIZERS</p> <p>Hammermill and Hog2.5</p> <p>Roller2.0</p> <p>PUMPS</p> <p>Centrifugal Constant Speed 1.1</p>	<p>Frequent Speed Changes under Load2.0</p> <p>Descaking,with accumulators2.0</p> <p>Gear,Rotary, or Vane1.75</p> <p>Reciprocating</p> <p>1 cyl.,single or double act.3.0</p> <p>2 cyl.,single acting3.0</p> <p>2 cyl.,double acting2.5</p> <p>3 or more cyliders2.0</p> <p>SCREENS</p> <p>Air Washing1.5</p> <p>Grizzly3.0</p> <p>Rotary Coal or Sand2.0</p> <p>Vibrating3.5</p> <p>Water1.5</p> <p>SKI TOWS & LIFTS(Not Approved)</p> <p>STEERING GEAR1.5</p> <p>STOKER1.5</p> <p>TUMBLING BARREL1.5</p> <p>WINCH,MANEUVERING</p> <p>Dredge,Marine2.5</p> <p>WINDLASS2.0</p> <p>WOODWDORKING2.0</p> <p>MACHINERY1.5</p> <p>WORK LIFT PLATFORMS(Not approved)</p> <p>Aphabetical listing of industries</p> <p>AGGREGATE PROCESSING, CEMENT, MINING KILNS: TUBE,ROD AND BALL MILLS</p> <p>Direct or on L.S. shaft of Reducer, with final drive Machined Spur Gears3.0</p> <p>Single Helical or Herringbone Gears2.25</p> <p>Conveyors,Feeders,Screens, Elevators,See General Listing</p> <p>Crushers,Ore or Stone3.5</p> <p>Dryer, Rotary2.0</p> <p>Grizzly3.0</p> <p>Hammermill or Hog2.5</p> <p>Tumbling Mill or Barrel2.5</p> <p>BREWING AND DISTILLING</p> <p>Bottle and Can Filling Machines1.5</p> <p>Brew Kettle1.5</p> <p>Cookers,Continuous Duty1.75</p> <p>Lauter Tub2.25</p> <p>Mash Tub1.75</p> <p>Scale Hopper,Frequent Peaks2.25</p> <p>CLAY WORKING INDUSTRY</p> <p>Brick Press, Briquette Machine, Clay Working Machine, Plug Mill2.5</p>
---	---	--

- a. In case of a slide coupling that axial movement occurs more than five times per hour, add 0.5 to the service factor. When electric motors, generators, engines, compressors and other machines are assembled with sleeves or straight roller bearings, axial end float couplings should be used to protect the bearings. When ordering, also order limited end float discs with the coupling.
- b. *Contact us for a balanced opposed design.
- c. ▲When using in a place with risk to human safety, for safety reasons, consult us before using.
- d. ★ Contact us for high peak load applications (such as Metal Rolling Mills)
- e. Non-reversing safety factor: The required coupling torque is the same as the peak torque.
- f. Reversing safety factor: The required coupling torque is twice the peak torque.

Engine Drive Service Factors







It is necessary to use a service factor for engine drives when the application involves good flywheel regulation to prevent torque fluctuations that are greater than ± 20%. If the torque fluctuation is greater, or if operation is close to serious critical or torsional vibration, a mass elastic study will be required.

To use Table 2, begin by selecting an application service factor from Table 1. Use that service factor to choose the appropriate engine service factor from Table 2. If the service factor from Table 1 is more than 2.5, please submit the complete application details to the factory for an engineering review.

Table 2. Engine Drive Service Factors

Number of cylinders	4 or 5					6 or more				
Service Factor	1.5	1.75	2.0	2.25	2.5	1.5	1.75	2.0	2.25	2.5
Engine Service Factor	2.5	2.75	3.0	3.25	3.5	2.5	2.75	3.0	3.25	3.5

For best results, measure the system characteristics with a torque meter. The service factors provided here are only a guide based on the usual ratio between the coupling catalogue rating and general system characteristics.

Torque Demands Driven Machine	Typical applications for Driven Equipment	Typical Service Factor
	Constant torque such as Centrifugal Pumps, Blowers and Compressors.	1.0
	Continuous duty with some torque variations including Plastic Extruders, Forced Draft Fans.	1.5
	Light shock loads from Metal Extruders, Cooling Towers, Cane Knife, Log Haul.	2.0
	Moderate shock loading as expected from a Car Dumper, Stone Crusher, Vibrating Screen.	2.5
	Heavy shock load with some negative torques from Roughing Mills, Reciprocating Pumps, Compressors, Reversing Runout Talbes.	3.0
	Applications like Reciprocating Compressors with frequent torque reversals, which do not necessarily cause reverse rotations.	Refer to WCC

Shrink Heating

1. Introduction

Heat shrinking is necessary and practical in industries that require more power and precision than is possible with other fitting methods.

2. Interference

1/1,000 to 15/10,000 (mm) of the shaft diameter d

3. Methods and Procedures for Fitting

- If you use a key, put the key on the shaft first and lubricate it. If there is no key, do not apply lubricant.
- Before fitting the hub on to the shaft, with the steel flexible coupling insert the tv cover and oil seal first. In case of the gear coupling, insert the sleeve, side cover first.
- To heat, choose one of the following methods and heat to 135°C:

- Oxy-acetylene or blow-torch heating Mark near the surface of the hub with a crayon that melts at 135°C. Then pass the flame through the inner diameter to heat it. Do not put heat directly on the tooth surface during heating, or heat only one side.
- Heating in a furnace Set the thermometer to 135°C and heat for at least three minutes per 1mm thickness. Avoid direct contact with heat sources during heating.
- Oil bath heating Put the hub in oil with a boiling point of 177°C or higher and heat it for six minutes per 1mm thickness. Do not let the surface of the hub touch the bottom of the container during heating.

4. Mount the hub as soon as possible to prevent heat loss.